

UNIVERSAL SALT / PEPPER MILL KIT (8" & 10")

Kit Features:

- Professional Grade Mechanism
- Adjustable ceramic grinder for salt crush & pepper (Non corrosive)
- New easy mount grinder capsule assembly™
- Minimum assembly parts

Required Accessories:

- 1-1/16" forstner bit #FB1-116
- 1-1/2" forstner bit #FB150
- 7mm bit #PK-7MMSG
- 1-1/2" jam chuck # CJAM15
- 60° live center
- Grinder positioning jig (see dia. C)
- 3 jaw drill chuck
- Epoxy glue

Wood Required:

- 8" style: 2-1/2" sq. (min. size) x 9" long
- 10" style: 2-1/2" sq. (min. size) x 12" long



DIAGRAM A / PARTS LAYOUT

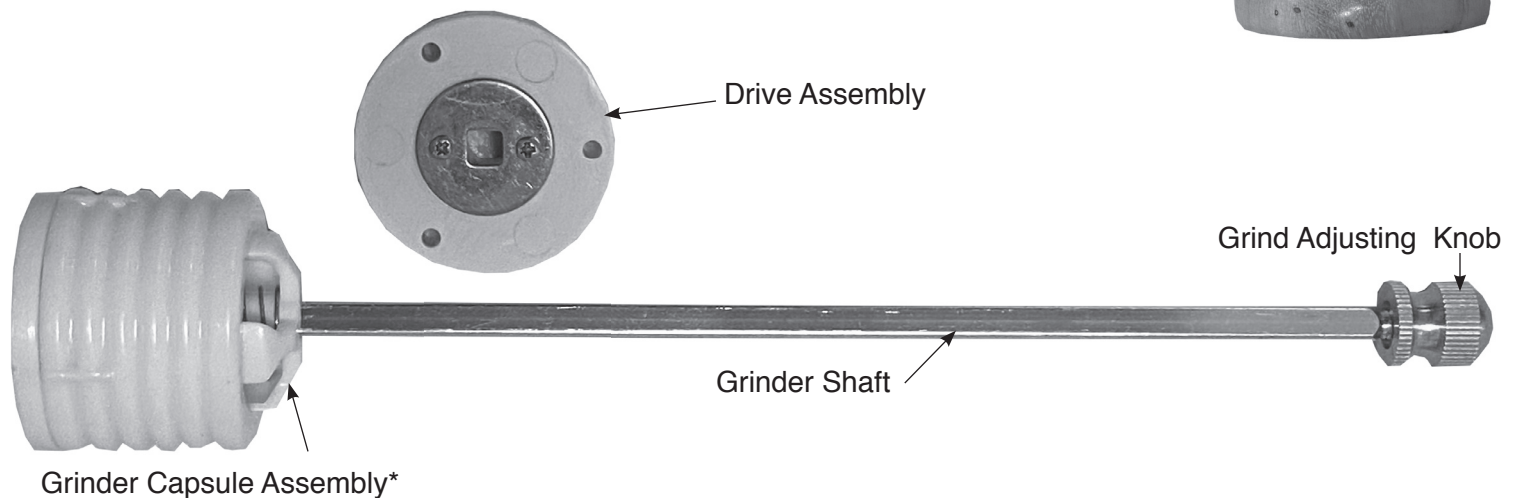

**Grinder Capsule Assembly includes spring, grinder, shaft, knob and mounting components screws mount into mill housing.*

Preparing the Blank:

- Cut (2) 2-1/2" sq. blanks at 90° to size required (see dia. B)
- Drill a 1-1/16" hole 5/16" deep in one end of the upper blank
- Follow with a 7mm hole through the same blank
- Drill a 1-1/2" hole through the lower blank

NOTE: *to assure a straight thru hole you may drill the blank halfway from each end, some off-center hole will not affect the function*

DIAGRAM B / TURNING THE BLANKS

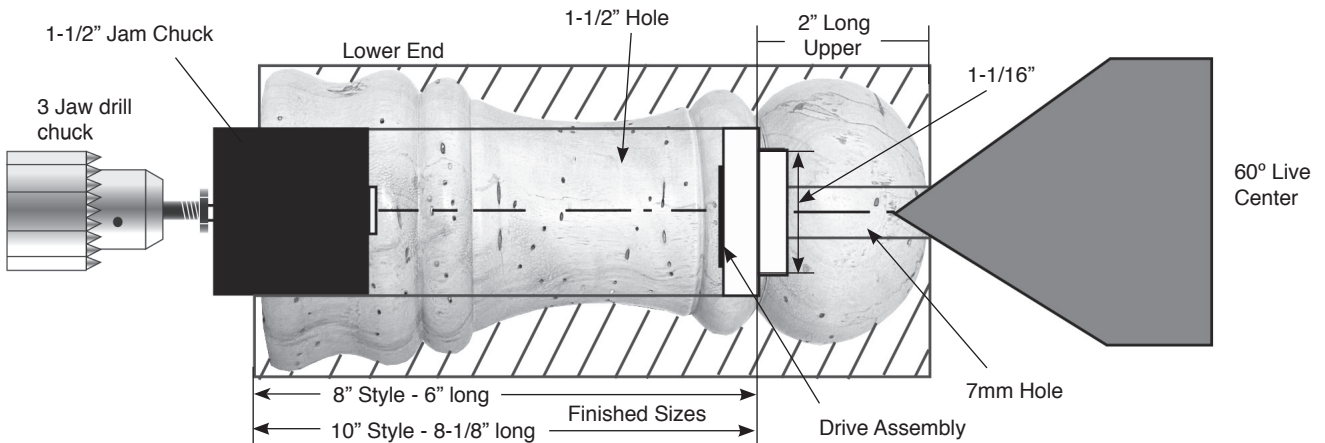
**Mounting & Turning the Blank (Dia B)**

- Insert the drive assembly into the hole at the bottom of the upper blank
- Secure the assembly into the wood with (3) screws
- Attach the drilling chuck and the jam chuck into the jaws
- Slide the lower blank over the jam chuck and follow with the top blank assembly and engage both ends
- Turn the nut (LEFT HAND THREADS) to expand into the hole.
- Slide the tailstock forward to engage, lock in place.
- Turn, sand, and use food safe finish to seal the wood

Assembly

*NOTE: in order to determine the position of the grinder capsule for gluing, a simple shop turned jig is helpful (diagram C)

- Glue the grinding capsule into the hole of the wooden base, 1/4" from the base
- Mix and spread epoxy glue over the ribs of the grinder assembly
- Insert the capsule through the bottom of the finished wood, to bottom over the jig (see diagram C)
- Place the grinder top over the shaft to the lower blank so the threaded shaft protrudes 3/8" over the top.
- Allow glue to dry once capsule is positioned.
- Thread the knob over the exposed threads.

Using the Mill

- Fill the chamber with pepper seeds or salt.
- Turn the grinder adjustment knob counter clockwise for course grind and clockwise for fine grind.

