

Press Top Pen Kit

REQUIRED ACCESSORIES:

- 7mm Pen Mandrel
- 2 piece Bushing Set #PKPT100BU
- 10mm Drill Bit #PK10-10
- Universal Trimming Kit #PKTRIMKIT (use 10mm shaft)
- Replacement Roller Refill #PK10-RPR
- Replacement Ink Cartridge #PK10-FPR
- 2 part epoxy glue or insta-cure (cyanoacrylate) glue
- Overall length 5-1/2" (closed)



DIAGRAM A • Parts List

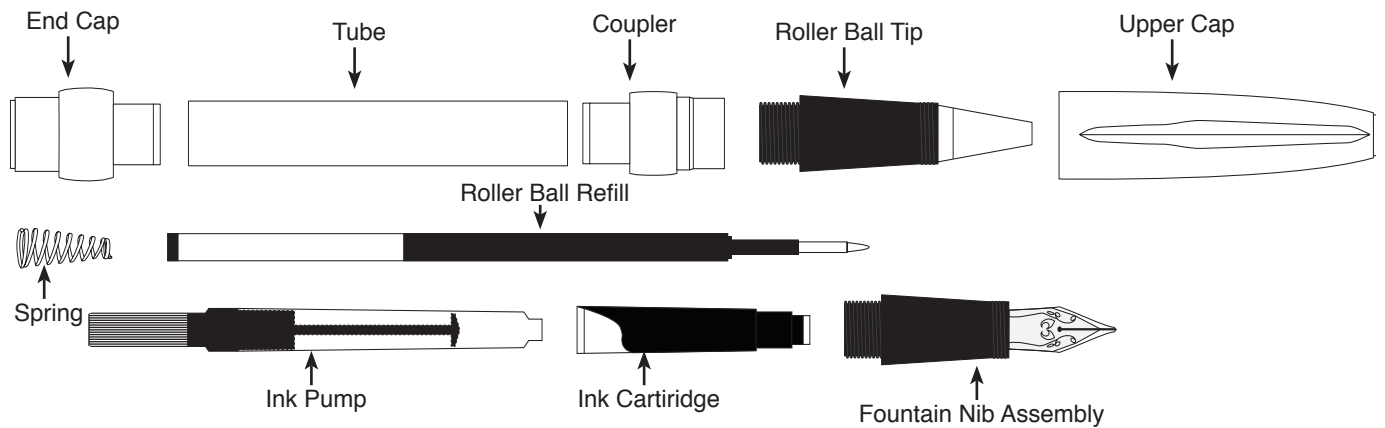

PREPARING THE BLANK:

- Cut 3/4" square blank to the length of the brass tube (add 1/16" for squaring off).
- Drill a 10mm center hole lengthwise through the blank.
- Spread the glue over the tube. Insert the tube into the blank with a twisting motion to spread the glue evenly inside. Center the tube lengthwise in the blank.
- When the glue dries, square the ends of the blank. Use 10mm barrel trimmer, a universal pen blank squaring jig or a belt/disc sander to square the ends. Take the wood down flush to the brass tube.

DIAGRAM B • Turning the blank

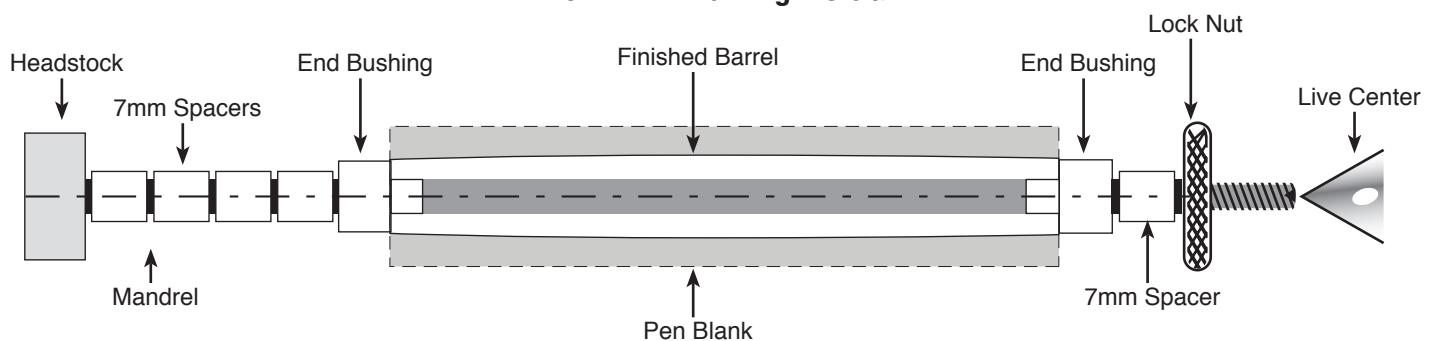

TURNING THE BLANK:

- Place bushings and blank on the mandrel according to Diagram B.
- Thread on the lock nut and hand tighten to hold all items in place.
- Slide the tailstock to the mandrel shaft, (do not overtighten, it could damage the mandrel). Lock in place.
- Turn the wood down, flush with the bushings using lathe tools.
- Sand the barrel gradually increasing the grades of sandpaper.
- Finish the wood with appropriate polish.

PEN ASSEMBLY

NOTE: Layout finished parts according to Diagram A

- Press the coupler into one end of the barrel.
- Press the end cap into the opposite end of the barrel.

FOUNTAIN ASSEMBLY

- Insert the ink cartridge into the back end of the fountain nib assembly. Push in and squeeze on the cartridge to push the ink forward, toward the nib.
- OR – when using the refillable ink pump, push the clear end of the cartridge into the opening of the nib assembly until it clicks. Screw the inner shaft counter clockwise all the way down inside the cartridge. Now, dip the nib into an ink bottle and slowly turn the shaft upwards (clockwise) to draw ink in, until the reservoir is filled. Screw the nib assembly back into the barrel.
- Screw in the fountain nib assembly into the coupler.
- Screw the cap over the pen tip when not in use.

ROLLER BALL ASSEMBLY

- Drop the spring, large end first into the opening at the pen barrel.
- Remove the protective cap off the refill and insert into the opening.
- Screw the tip over the refill into the coupler.
- Screw the cap over the pen nib when not in use.

CAP INSTALLATION

- The cap screws onto nib end and the cap presses onto the end cap.

DIAGRAM C • Bushings / PKPT100BU